

# MCM 37X



## Technical Specifications

### ■ Engine

Machine	37X
Model	Xinchai A498BT1
Type	Direct Injection, Water Cooled
No. of Cylinders	Diesel Stage-III 4-cylinder Engine
Net Peak Power	36.8kW (49.3HP) @ 2400 rpm
Fuel Tank Capacity	85 Litres
Vehicle Speeds	18-28km/h

### ■ Hydraulic System

Circuit Type	Open Centre, gear type	
Pump Capacity (@ 1,900 rpm)	L/min	85.5
System Pressure	Mpa	18
Tank Capacity	L	80
Steering Type	4WD	
Power Steering	Hydrostatic	

### ■ Operation Dimensions

<b>A</b> Total Travel Length	mm	6000
<b>B</b> Total Travel Height	mm	2900
<b>C</b> Total Travel Width	mm	1850
<b>D</b> Stabilizers Extended Width	mm	3350
<b>E</b> Wheel Base	mm	2050
<b>F</b> Front Axle to Bucket Edge	mm	2250
<b>G</b> Backhoe Reach from Rear Axle	mm	5950

### ■ Attachments

Augers	Breakers	Brush Cutters	Buckets	Earth Drills
Forks	Grapples	Rippers	Shears	Trenchers

### ■ Other

Under our policy of continuous improvement, we reserve the right to change technical data and design without prior notice.

Dealer Info:

### ■ Operation Parameters

Operating Weight	kg	5000
<b>Backhoe Parameters</b>		
Backhoe Bucket Capacity	m <sup>3</sup>	0.2
<b>H</b> Max. Digging Depth	mm	3400
<b>I</b> Max. Working Height	mm	5000
Max. Digging Radius	mm	4600
Rotation Angle of Boom	degrees	180
<b>Loader Parameters</b>		
Loader Bucket Capacity	m <sup>3</sup>	0.8
Rated Loading Weight	kg	1600
<b>J</b> Max. Lift Height	mm	3700
<b>K</b> Max. Dumping Height	mm	2700
Dumping Distance	mm	1000
Min. Turning Distance	mm	4800
Bucket Breakout Force	kN	52

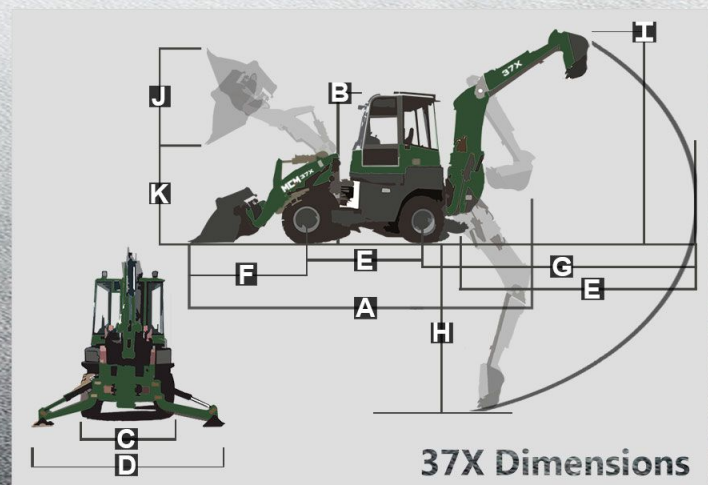

37X Dimensions