

# **CHANGCHAI ZN390T ENGINE PARTS MANUAL**

# CONTENTS

1.Cylinder Head Cover Assembly.....	4
2.Cylinder Head Assembly.....	6
3.Cylinder Block and Gear Case Assembly.....	8
4.Timing Gear Train.....	12
5.Piston and Connecting Rod Assembly.....	14
6.Crankshaft and Flywheel Assembly.....	15
7.Timing Mechanism.....	16
8.Water Pump and Fan Assembly.....	18
9.Oil Sump Assembly.....	20
10.Lubricating Oil Pump Assembly.....	21
11.Fuel System.....	22
12.Oil Suction Strainer Assembly.....	24
13.Breather Assembly.....	25
14.Oil Filter/Air Filter/Generatr/Starting Motor/Silencer.....	26
15.Tension pulley assembly.....	27



图1 气缸盖罩总成

Fig.1 Cylinder head cover assembly

气缸盖罩总成(图 1)

Cylinder Head Cover Assembly(Fig.1)

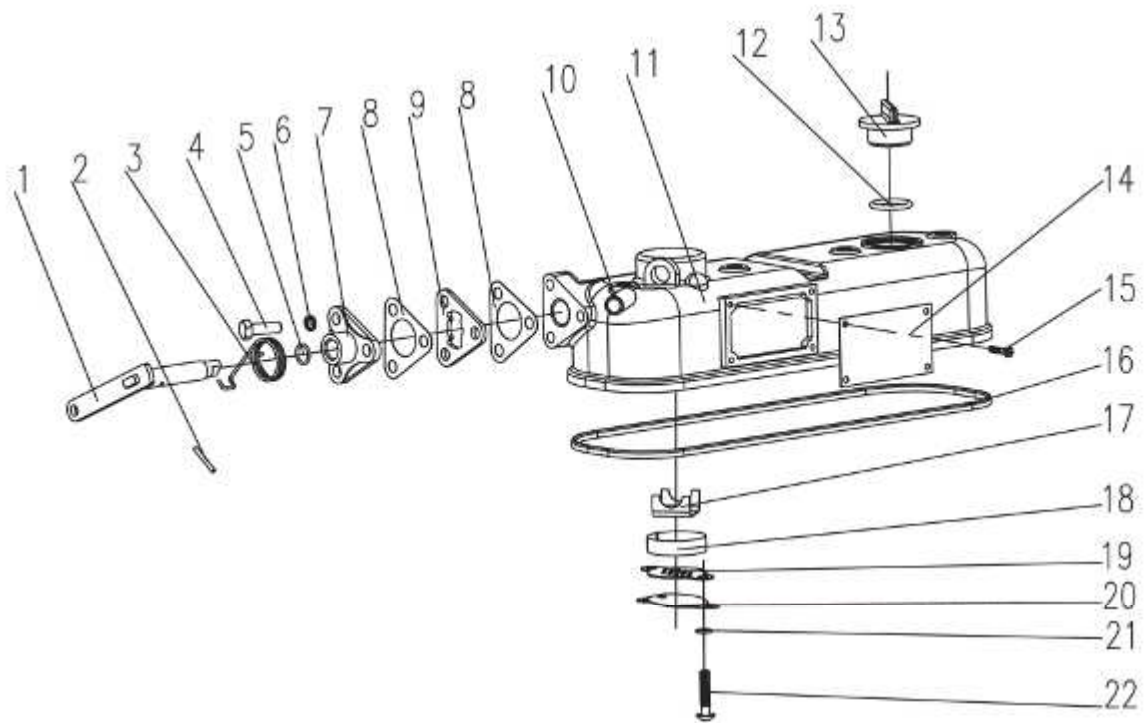
序号 Ref.No.	名称 Name of parts	零、部件号 Part No.	数量 Quantity
1	减压摇臂焊件 Decompression lever	N390T-01400	1
2	限位销 Stop pin	90-11005	1
3	扭力弹簧 Torsional spring	N390T-01016	1
4	螺栓 Bolt M8×22	GB/T5781-86	3
5	O 型密封圈 Blot ring 10.6×1.8	GB/T34521-82	1
6	垫圈 Washer 8	GB/T859-87	3
7	减压摇臂轴套 Decompression lever bushing	N390T-01015	1
8	垫片 Gasket	85-11003	2
9	减压器控制板 Decompressor controlling plate	90-11004	1
10	抽气管 Breather tube	N85-01004	1
11	气缸盖罩 Cylinder head cover	N390T-01003	1
12	O 型密封圈 Seal ring 33.5×2.65oil filling cover	GB3452.1-82	1
13	加油口盖 Oil filling cover	N85-01002	1
14	铭牌 Name plate	ZN390T-01009	1
15	螺钉 Bolt M4×6	GB65-85	4
16	气缸盖罩密封圈 Cylinder head cover seal ring	N390T-01001	1
17	挡架 Retainer	N85-01005	1
18	铁丝滤网 Steel wool screen	N85-01008	1
19	多孔挡板 Multi-hole retaining plate	N85-01007	1
20	挡油板 Oil retainer	N85-01006	1
21	垫圈 Washer 6	GB859-87	2
22	螺钉 Screw M6×12	GB823-88	2



图2 气缸盖总成

Fig.2 Cylinder head assembly

气缸盖总成(图 2)

Cylinder Head Assembly(Fig.2)

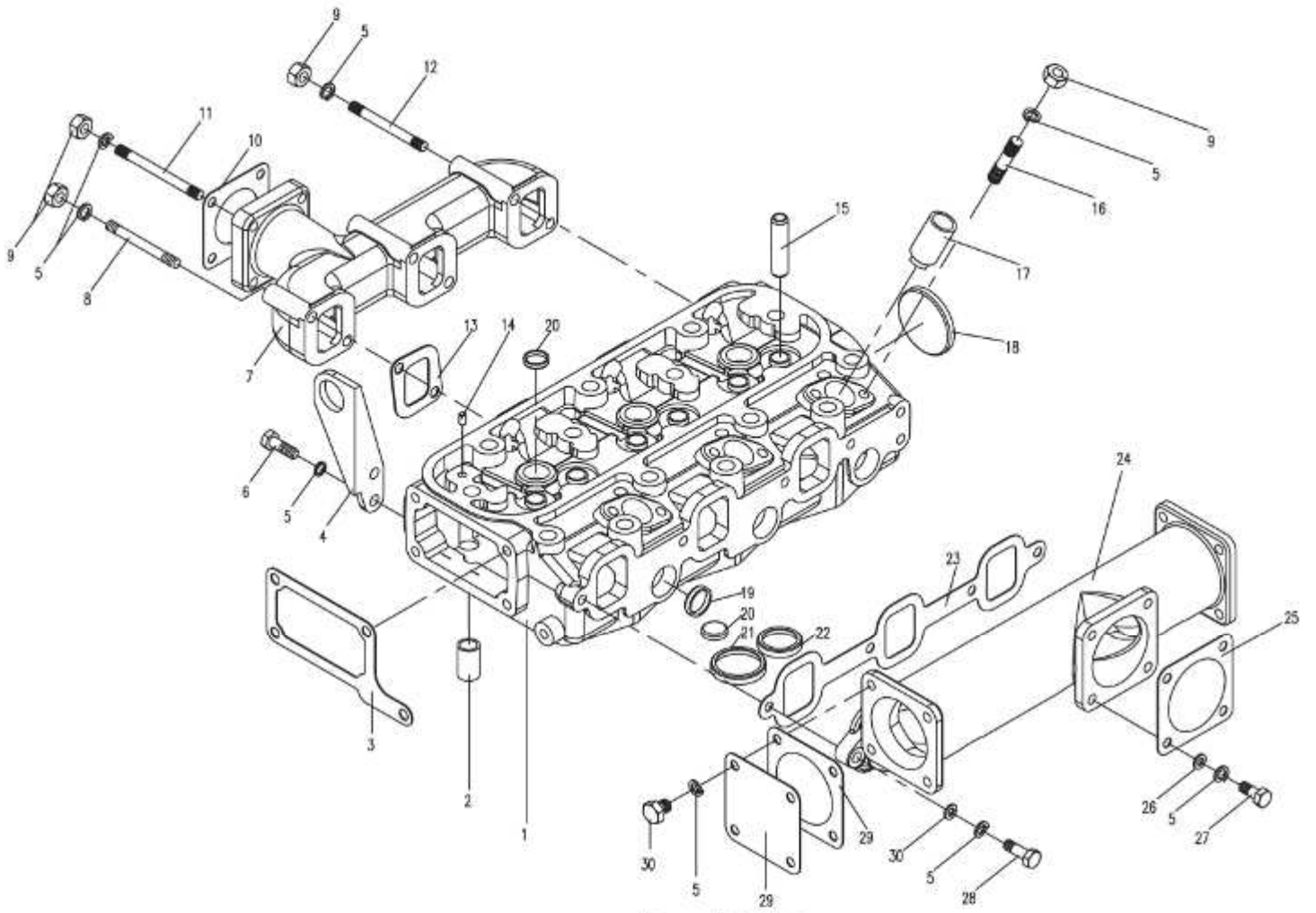
序号 Ref.No.	名称 Name of parts	零、部件号 Part No.	数量 Quantity
1	气缸盖 Cylinder head	ZN390T-02108	1
2	套管 Sleeve	N85-02101A	3
3	水泵联接板垫片 Water pump adapter gasket	N485T-08017	1
4	吊耳 Lifting eye	N85-02004	2
5	垫圈 Washer 8	GB859-87	36
6	螺栓 Bolt M8×20	GB5782-86	4
7	排气管 Exhaust manifold	ZN390T-10001	1
8	双头螺柱 Stud M8×60	GB899-88	2
9	螺母 Nut M8	GB6170-86	16
10	垫片 Gasket	N85T-20001	1
11	双头螺柱 Stud M8×85	GB899-88	4
12	双头螺柱 Stud M×75	GB899-88	4
13	排气管垫片 Exhaust manifold gasket	N90-02006	3
14	套管 Sleeve	N485QA-02110	1
15	气门导管 Valve guide	N85-02105	6
16	双头螺柱 Stud M8×55	GB899-88	6
17	喷油器镶套 Injector insert	CZ475Q-021005	3
18	碗形塞 Expansion plug Φ55	N85-02104	1
19	碗形塞 Expansion plug Φ26	N485-02109	3
20	碗形塞 Expansion plug Φ20	N485-02102	6
21	排气门座 Exhust valve seat	N85-02106	3
22	进气门座 Intake valve seat	N85-02107	3
23	进气管垫片 Intake manifold gasket	ZN390T-02005	1
24	进气管 Intake manifold	ZN390T-09001	1
25	垫片 Gasket	N485-09006	3
26	垫圈 Washer 8	GB97.1-85	8
27	螺栓 Bolt M8×20	GB5783-86	4
28	螺栓 Bolt M8×28	GB5782-86	4
29	盖板 Cover	N485-09005	2
30	螺栓 Bolt M8×16	GB5783-86	8



图3 机体、齿轮室总成  
 Fig.3 Cylinder block and gear case assembly

机体、齿轮室总成（图3）

Cylinder Block and Gear Case Assembly(Fig.3)

序号 Ref.No.	名称 Name of parts	零、部件号 Part No.	数量 Quantity
1	螺栓 Bolt M10×25	GB578-86	10
2	螺栓 Bolt M12×25	GB5782-86	2
3	垫圈 Washer 12	GB859-87	2
4	垫圈 Washer 10	GB859-87	12
5	飞轮壳 Flywheel housing	N485T-03012	1
6	油封 Oil seal DL85×110×12	HG4-692-67	1
7	螺栓 Bolt M8×25	GB5783-86	7
8	垫圈 Washer 8	GB859-87	46
9	垫圈 Washer 8	GB848-85	42
10	塞片 Expansion plug	N85-03108	1
11	凸轮轴后衬套 Camshaft rear bushing	N85-03109	1
12	碗形塞 Expansion plug S30	N85-03102	4
13	凸轮轴中间衬套 Camshaft middle bushing	N85-03112	1
14	机油尺部件 Oil dipstick	N85T-03300	1
15	气缸盖定位套 Cylinder head locating sleeve	N85-03017	2
16	气缸盖螺栓垫圈 Cylinder head bolt washer	N85-03014	14
17	气缸盖螺栓 Cylinder head bolt	N85-03015	14
18	气缸套 Cylinder liner	N90-03003	3
19	封水圈 Water seal ring	N90-03002	6
20	气缸盖垫片 Cylinder head gasket	ZN390T-03013	1
21	机体 Cylinder block	N390T-03101	1
22	凸轮轴衬套 Camshaft bushing	N85-03103	1
23	齿轮室垫片 Gear case gasket	N85-12001	1
24	螺母 Nut M8	GB6170-86	3
25	螺栓 Bolt M8×35	GB899-88	3
26	齿轮室 Gear case	N85T-12002	1
27	螺母 Nut M10	GB6170-86	1
28	垫圈 Washer 10	GB93-87	1
29	发电机支架 Generator bracket	N85T-12007	1
30	螺栓 Bolt M8×20	GB5782-86	6
31	螺栓 Bolt M10×90	GB5782-86	1
32	轴承 Bearing 107	GB276-82	2
33	齿轮室盖垫片 Gear case cover gasket	N85T-12003	1
34	齿轮室盖 Gear case cover	N85T-12004	1
35	螺栓 Bolt M8×65	GB5782-86	3
36	螺栓 Bolt M8×40	GB5782-86	1
37	螺栓 Bolt M8×30	GB5782-86	2
38	液压泵盖垫片 Hydraulic pump cover gasket	N85T-12010	2
39	液压泵盖 Hydraulic pump cover	N85T-12009	2
40	螺栓 Bolt M8×25	GB5782-86	11
41	油封 Oil seal DR52×72×12	HG4-692-67	1

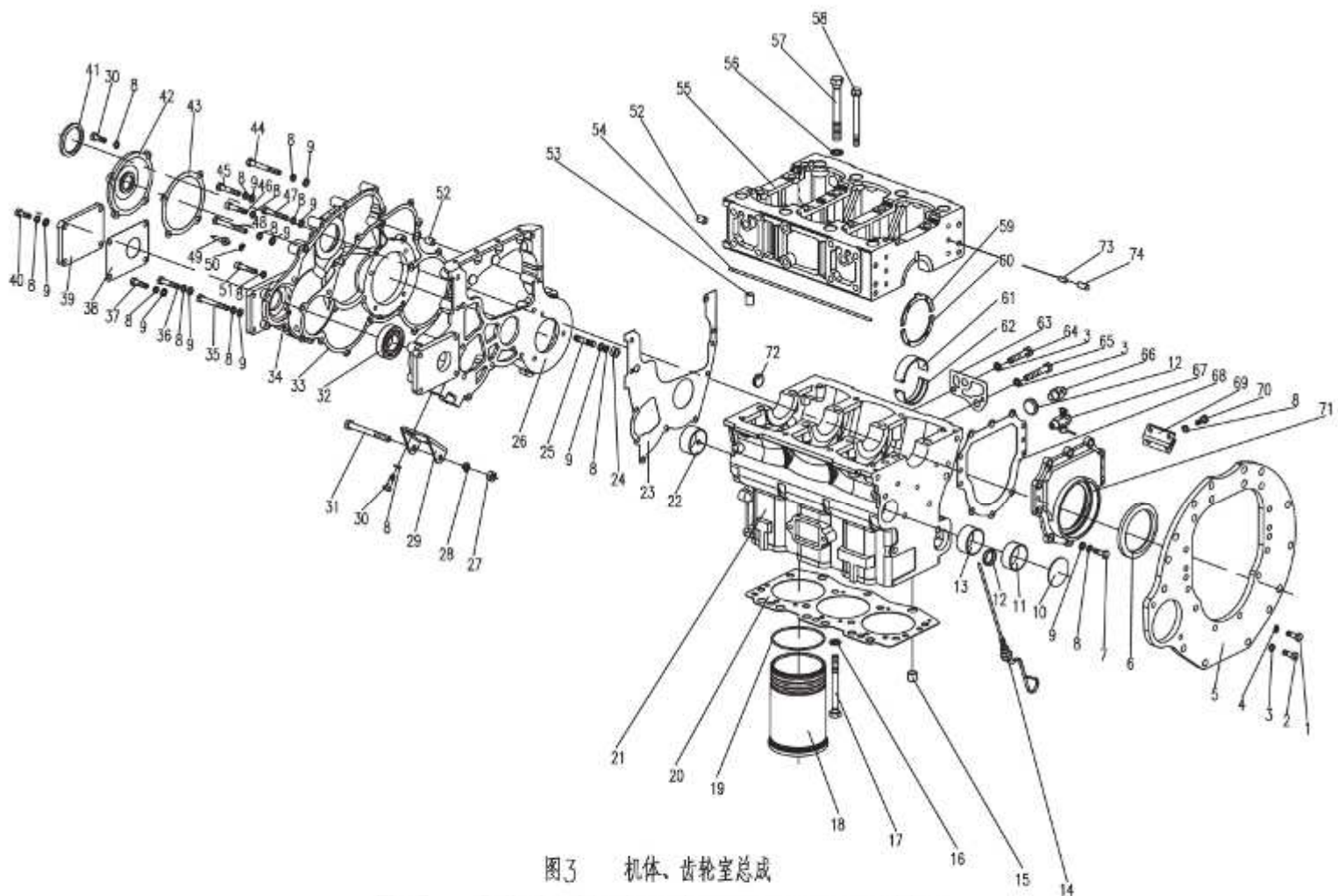

42	齿轮室前盖 Gear case front cover	N485T-12005	1
43	液压泵盖 Gear case front cover gasket	N485T-12006	1
44	螺栓 Bolt M8×80	GB5782-86	1
45	螺栓 Bolt M8×45	GB5782-86	3
46	内六角圆柱头螺钉 Inner hexagon cylindrical bolt M8×55	GB70-85	1
47	螺栓 Bolt M8×50	GB5782-86	2
48	螺栓 Bolt M8×75	GB5782-86	1
49	上止点指针 T.D.C. pointer	N85T-12008	1
50	垫圈 Washer 6	GB859-87	1
51	内六角圆柱头螺钉 Inner hexagon cylindrical bolt M8×20	GB70-85	3
52	齿轮室定位套 Gear case locating sleeve	N85-03001	3
53	定位销 Dowel pin	N85T-03110	2
54	O形密封条 O-ring seal rod	N485T-03020	2
55	整体主轴盖 Monolithic main shaft cover	N390T-03115	1
56	主轴承盖螺栓垫圈 Main shaft cover bolt washer	N85-03105	8
57	主轴承盖螺栓 Main shaft cover bolt	N85T-03107	8
58	床板螺栓 Main bearing cap bolt	N85T-03108	8
59	曲轴止推片(下)Crankshaft thrust plate(lower)	N85-03007	2
60	曲轴止推片(上)Crankshaft thrust plate(upper)	N85-03009	2
61	主轴瓦(下)Main bearing shell(lower)	N85-03006	4
62	主轴瓦(上)Main bearing shell(upper)	N85-03008	4
63	机油滤清器垫片 Lubricating oil filter gasket	N85T-03020	1
64	螺栓 Bolt M10×35	GB5782-86	1
65	螺栓 Bolt M10×70	GB5782-86	1
66	机油压力传感器 Oil pressure sensor	N85-03004	1
67	放水阀部件 Water draining cock	N85-03200	1
68	后油封盖垫片 Rear oil seal cover gasket	N85T-03005	1
69	柴油滤清器支架 Fuel filter support	N390T-03024	1
70	螺栓 Bolt M8×20	GB5783-86	4
71	后油封盖 Rear oil seal cover	N85T-03010	1
72	堵塞 Blocking plug	N85-03111	4
73	销 Pin B8×16	GB119-86	2
74	销 Pin B10×22	GB119-86	2



图4 正时齿轮系总成  
Fig.4 Timing gear train

## 正时齿轮系总成(图 4)

## Timing Gear Train(Fig.4)

序号 Ref.No.	名称 Name of parts	零、部件号 Part No.	数量 Quantity
1	螺栓 Bolt M12×30	GB5782-86	1
2	垫圈 Washer 12	GB859-87	1
3	凸轮轴正时齿轮压板 Camshaft timing gear retainer	N85-04009	1
4	液压泵齿轮 Hydraulic pump gear	N85T-04011A	1
5	凸轮轴正时齿轮 Camshaft timing gear	N85T-04007	1
6	螺栓 Bolt M8×16	GB5782-86	2
7	垫圈 Washer 8	GB859-87	4
8	垫圈 Washer 8	GB97.1-85	2
9	凸轮轴压板 Camshaft retainer	N85-04008	1
10	正时惰齿轮衬套 Timing idle gear bushing	N85-04002	1
11	正时惰齿轮轴 Timing idle gear shaft	N85T-04004	1
12	空心螺栓 Hollow bolt	N85T-04012	1
13	垫圈 Washer	195-09001-1	2
14	喷油管部件 Oil pipe	N85T-04100	1
15	螺栓 Bolt M8×50	GB5782-86	2
16	正时惰齿轮压板 Timing idle gear retainer	N85T-04003	1
17	螺栓 Bolt M6 <sup>^</sup> 25	GB5783-86	6
18	垫圈 Washer 6	GB859-87	6
19	联接盘 Adapter	N485T-32001A	1
20	机油泵主动齿轮 Lubricating oil pump driving gear	N85-04001	1
21	曲轴正时齿轮 Crankshaft timing gear	N85-04006	1
22	正时惰齿轮 Timing idle gear	N85-04005	1
23	燃油泵正时齿轮 Injection pump timing gear	N485T-04001	1

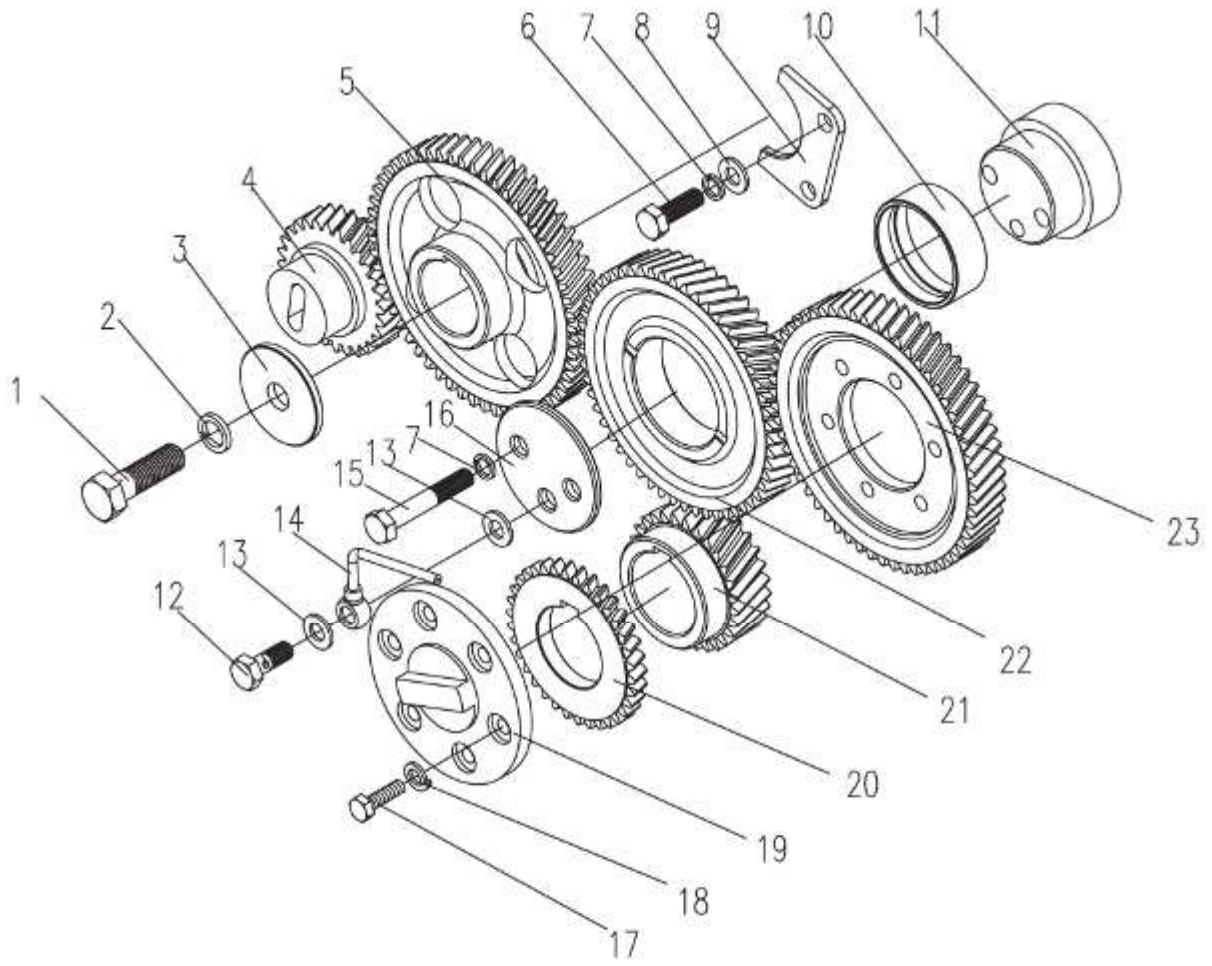

图5 活塞、连杆总成

Fig.5 Piston and connecting rod assembly

活塞、连杆总成（图5）

**Piston and Connecting Rod Assembly(Fig.5)**

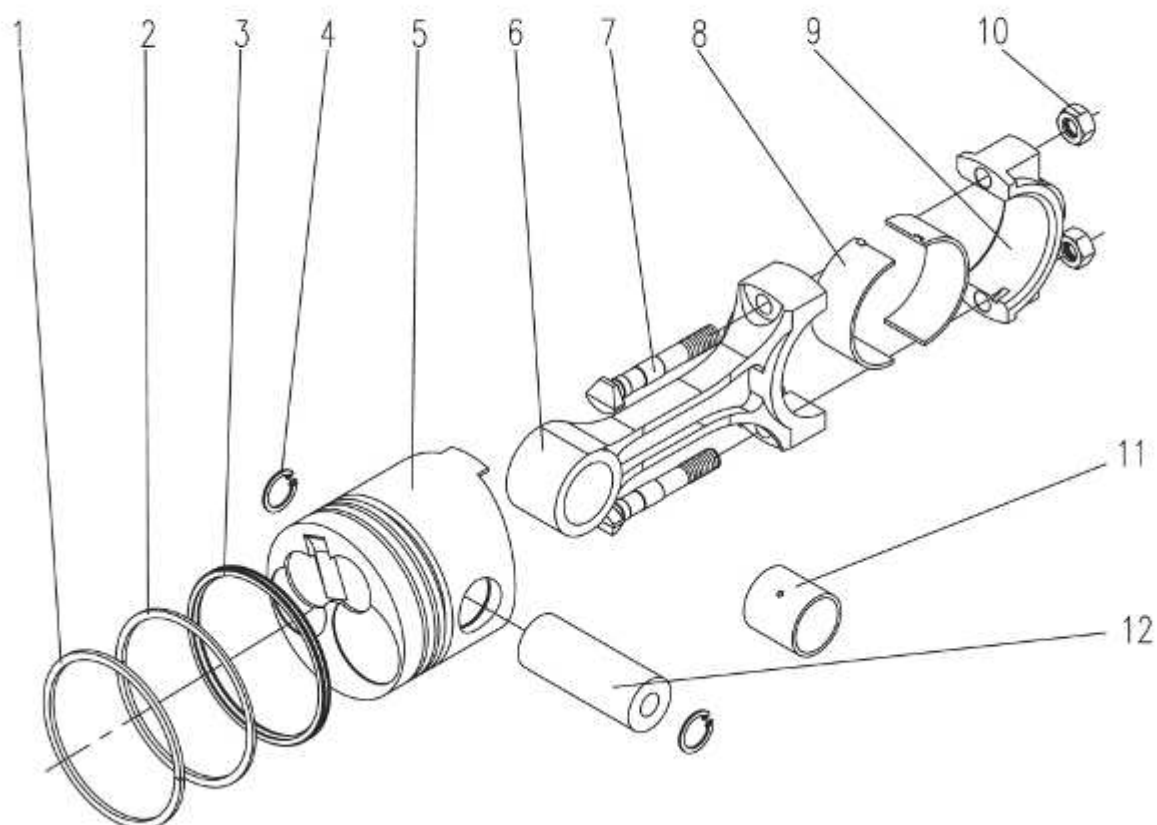
序号 Ref.No.	名称 Name of parts	零、部件号 Part No.	数量 Quantity
1	第一道活塞环 1st piston ring	ZN90QA-05002	3
2	第二道活塞环 2nd piston ring	N90-05003	3
3	油环部件 Oil ring	N90-05100	3
4	挡圈 Circlip 28	GB8932-86	6
5	活塞 Piston	ZN90QA-05001	3
6	连杆 Connecting rod	N85-03201	3
7	连杆螺栓 Connecting rod bolt	N85-05203	6
8	连杆轴瓦 Connecting rod bearing shell	ZN85QA-05005	6
9	连杆盖 Connecting rod cap	N85-05204	3
10	连杆螺母 Connecting rod nut	N85-05205	6
11	连杆衬套 Connecting rod bushing	N85-05202	3
12	活塞销 Piston pin	N85-05004	3



图6 曲轴飞轮总成

Fig.6 Crankshaft and flywheel assembly

曲轴、飞轮总成（图6）

Crankshaft and Flywheel Assembly(Fig.6)

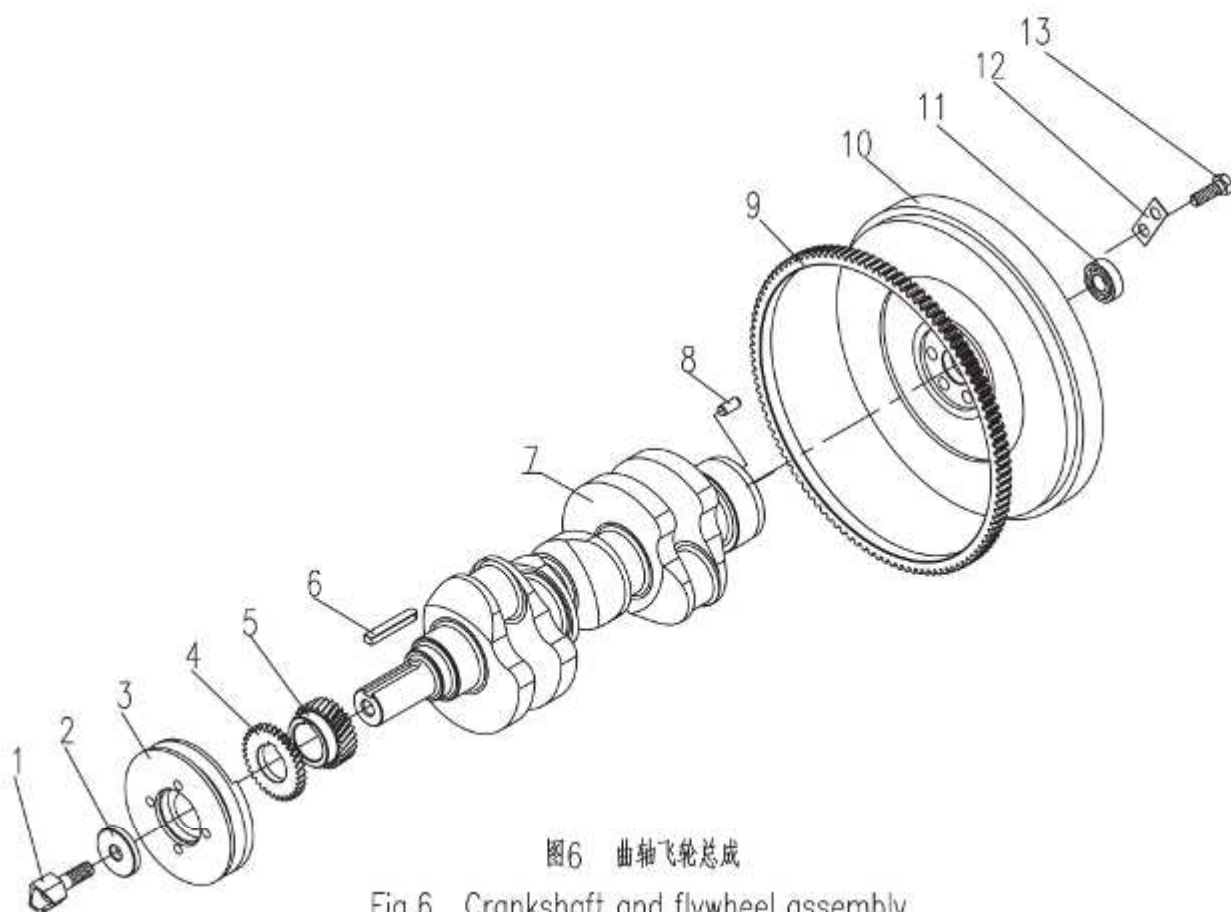
序号 Ref.No.	名称 Name of parts	零、部件号 Part No.	数量 Quantity
1	起动爪 Staring jaw	N85-06003	1
2	起动爪垫圈 Staring jaw washer	N85T-06002	1
3	曲轴皮带轮 Crankshaft pulley	N390T-06001	1
4	机油泵主动齿轮 Lubricating oil pump driving gear	N85-04010	1
5	曲轴正时齿轮 Crankshaft timing gear	N85-04006	1
6	键 Key C10×63	GB1096-79	1
7	曲轴 Crankshaft	N385-06004	1
8	销 Cylindrical pin B10×20	GB119-86	1
9	飞轮齿圈 Flywheel ring gear	N485-06102	1
10	飞轮 Flywheel	N90T-06101	1
11	滚动轴承 Ball bearing 104	GB276-64	1
12	飞轮螺栓垫片 Flywheel blot washer	N85-06005	3
13	飞轮螺栓 Flywheel blot	N85-06006	6



图7 配气机构

Fig.7 Valve timing mechanism

## 配气机构(图 7)

## Valve Timing Mechanism(Fig.7)

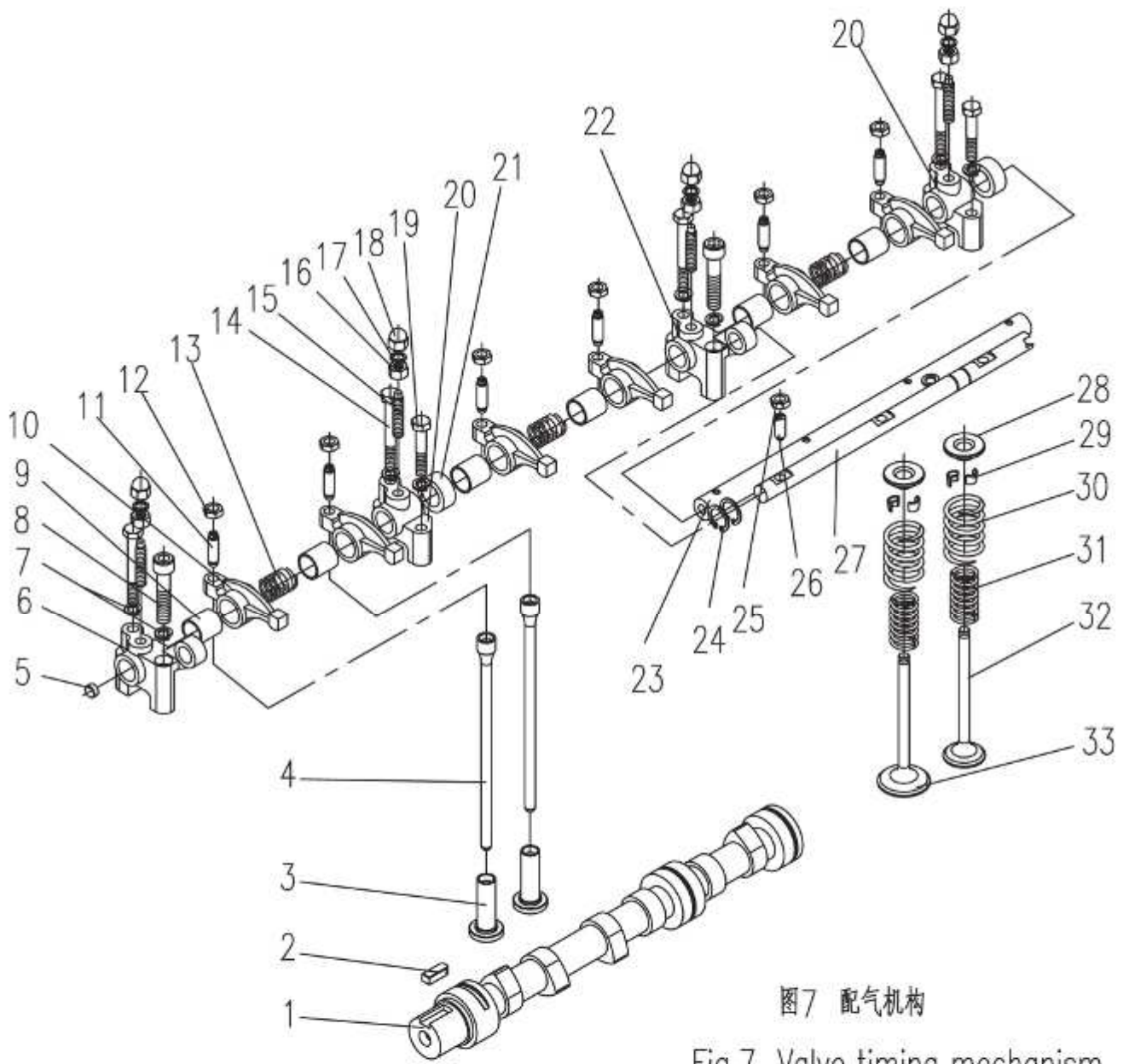
序号 Ref.No.	名称 Name of parts	零、部件号 Part No.	数量 Quantity
1	凸轮轴 Camshaft	N385-07001	1
2	平键 Flat key C10×25	GB1096-79	1
3	气门挺柱 Valve tappet	N85-07003	6
4	气门推杆 Valve push rod	N85-07002	6
5	堵塞 Blocking plug	N85-02208	2
6	前摇臂座 Front rocker arm support	N390T-02201	1
7	垫圈 Washer 8	GB859-87	6
8	螺钉 Screw M8×45	GB70-85	3
9	气门摇臂衬套 Valve rocker arm bushing	N85-02212	6
10	气门摇臂 Valve rocker arm	N85-02211	6
11	气门间隙调整螺钉 Valve clearance adjusting screw	N85-02202	6
12	气门间隙调整螺母 Valve clearance adjusting nut	N85-02203	6
13	气门摇臂弹簧 Valve rocker arm spring	N85-02205	3
14	螺栓 Bolt M8×60	GB5782-86	4
15	螺钉 Screw M8×50	GB79-85	4
16	螺母 Nut M8	GB6170-86	4
17	垫圈 Washer 8	GB97.1-85	4
18	螺母 Nut M8	GB923-88	4
19	螺栓 Bolt M8×45	GB5782-86	2
20	摇臂座 Rocker arm support	N85-02204	2
21	轴套 Rocker arm shaft bushing	N85-02206	2
22	摇臂座 Rocker arm support	N390T-02204	1
23	摇臂轴 Rocker arm shaft	N385-02207	1
24	挡圈 Circlip 14	GB894.1-86	2
25	螺母 Nut M8×1	GB6172-88	3
26	减压调整螺钉 Decompression adjusting screw	N390T-01010	3
27	减压轴 Decompression shaft	N390T-01013	1
28	气门弹簧上座 Valve spring seat(upper)	N85-02001(1)	6
29	气门锁夹 Valve collet	N85-02002	12
30	气门外弹簧 Valve outer spring	N85-02003(1)	6
31	气门内弹簧 Valve inner spring	N85-02003(2)	6
32	排气门 Exhaust valve	N90-02007	3
33	进气门 Intake valve	N90-02008	3



图8 水泵风扇总成

Fig.8 Water Pump and Fan Assembly

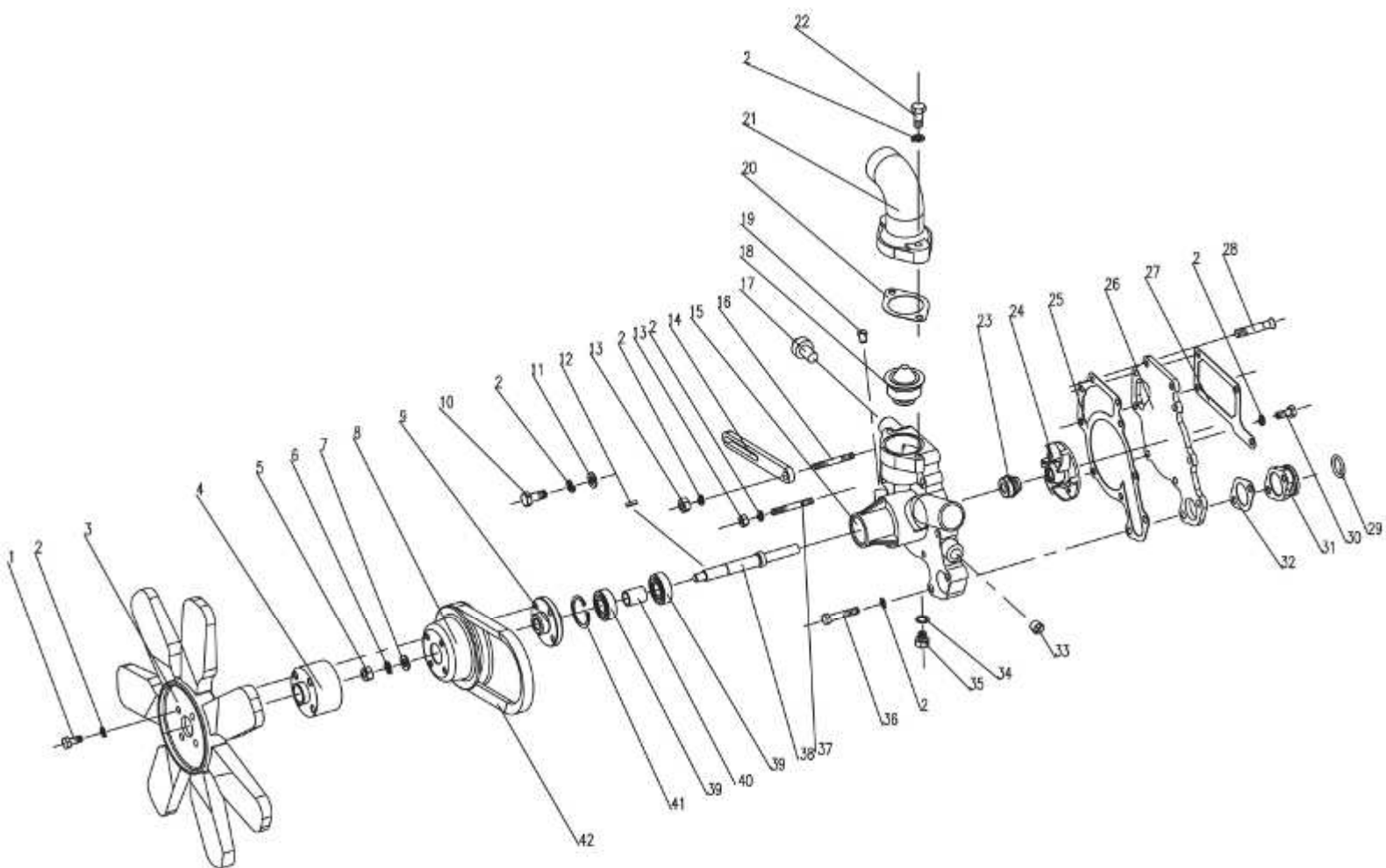

## 水泵、风扇总成(图 8)

Water Pump and Fan Assembly(Fig.8)

序号 Ref.No.	名称 Name of parts	零、部件号 Pare No.	数量 Quantity
1	螺栓 Bolt M8×60	GB5783-86	4
2	垫圈 Washer 8	GB859-87	15
3	冷却风扇 Cooling fan	N485-08001	1
4	风扇垫块 Fan pad	N390T-08019	1
5	螺母 Nut M10	GB6170-86	1
6	垫圈 Washer 10	GB859-87	1
7	垫圈 Washer 10	GB97.1-85	1
8	水泵皮带轮 Water pump pulley	N85Q-08011(1)	1
9	水泵皮带轮壳 Water pump pulley housing	N485T-08012	1
10	螺栓 Bolt M8×25	GB5783-86	1
11	垫圈 Washer 8	GB97.1-85	1
12	键 Key 4×36	GB1099-79	1
13	螺母 Nut M8	GB6170-86	4
14	撑杆 Bracing	N85T-08018	1
15	水泵壳体 Water pump housing	N85T-08004	1
16	螺柱 Stud M8×50	GB898-76	1
17	水温传感器 Water temperature sensor model 306		1
18	节温器 Thermostat (Model 155B)	N85Q-17003	1
19	油杯 Oil cup M8×1	GB1152-79	1
20	节温器壳垫片 Thermostat housing gasket	N85T-08008	1
21	节温器壳 Thermostat housing	N85T-08007	1
22	螺栓 Bolt M8×30	GB5783-86	2
23	水封 Water seal ring IF-12	N85T-08003	1
24	水泵叶轮 Water pump impeller	N85T-08005	1
25	水泵垫片 Water pump gasket	N85T-08009	1
26	水泵连接板 Water pump adapter	N85T-08010	1
27	水泵连接板垫片 Water pump adapter gasket	N85T-08017	1
28	螺钉 Screw M8×16	GB68-86	2
29	O 型密封圈 Seal ring 40×3.1	GB1235-76	1
30	螺栓 Bolt M8×20	GB5783-86	2
31	出水接头 Water drain connector	N85T-08013	1
32	出水接头垫片 Water drain connector gasket	N85T-08014	1
33	螺塞 Plug	N85T-08016	1
34	垫圈 Washer 12	GB3541-83	1
35	放水螺栓 Water drain screw	N85T-08015	1
36	螺栓 Bolt M8×45	GB5780-86	2
37	螺柱 Stud M8×45	GB898-76	3
38	水泵轴 Water pump shaft	N85T-08006	1
39	滚动轴承 Ball bearing 602020	GB278-82	2
40	轴承隔套 Bearing spacing sleeve	N85T-08002	1
41	挡圈 Circlip 35	GB93.2-85	1
42	风扇带 Fan belt 13×8×1060	HG4-401-66	1



图9 油底壳总成

Fig.9 Oil Sump Assembly

油底壳总成(图 9)

Oil Sump Assembly (Fig.9)

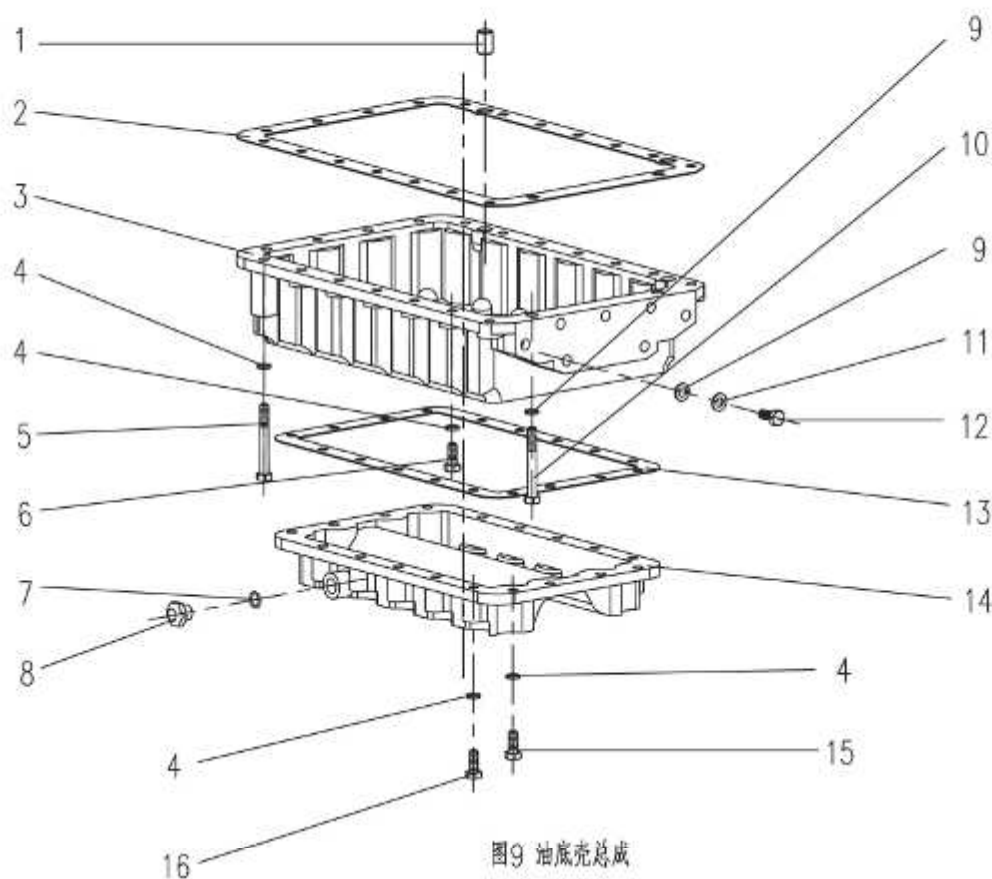
序号 Ref.No.	名称 Name of parts	零、部件号 Part No.	数量 Quantity
1	定位销 Dowel pin	N485T-03110	2
2	油底壳垫片 Oil sump gasket	N390T-11001-1	1
3	油底壳 Oil sump	N390T-11004-1	1
4	垫圈 Washer 8	GB93-87	39
5	螺栓 Bolt M8×55	GB5782-86	1
6	螺栓 Bolt M8×30	GB5783-86	17
7	O形密封圈 Seal ring	GB1235-76	2
8	闷头 Plug	195-01026	2
9	垫圈 Washer 10	GB93-87	6
10	螺栓 Bolt M10×30	GB5782-86	2
11	垫圈 Washer 10-100HV	GB95-85	4
12	螺栓 Bolt M10×30	GB5783-86	4
13	副油底壳垫片 Auxiliary oil sump gasket	N390T-11005-1	1
14	副油底壳 Auxiliary oil sump	N390T-11006-1	1
15	螺栓 Bolt M8×25	GB5783-86	11
16	螺栓 Bolt M8×45	GB5783-87	10



图10 机油泵总成

Fig.10 Lubricating Oil Pump Assembly

机油泵总成(图 10)

Lubricating Oil Pump Assembly (Fig.10)

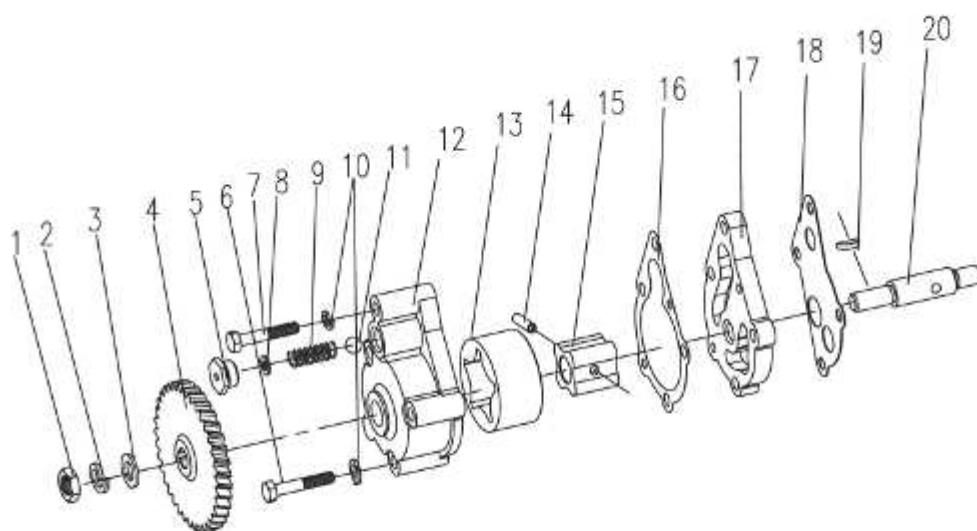
序号 Ref.No.	名称 Name of parts	零、部件号 Part No.	数量 Quantity
1	螺母 Nut M10×1	GB6173-86	1
2	垫圈 Washer 10	GB859-87	1
3	垫圈 Washer 10	GB848-85	1
4	机油泵齿轮 Oil pump gear	N85-13007(A)	1
5	限压阀塞 Pressure-limiting plug	N85-13006	1
6	螺栓 Bolt M6×50	GB5782-86	3
7	螺栓 Bolt M6×55	GB5782-86	1
8	垫圈 Washer 4	GB859-87	4
9	限压弹簧 Pressure-limiting spring	N85-13005	1
10	垫圈 Washer 6	GB859-87	4
11	钢球 Steel ball	GB308-77	1
12	机油泵体 Oil pump body	N485-13001(A)	1
13	外转子 Outer rotor	N485-13004(A)	1
14	圆柱销 Cylindrical pin	N85-13103(A)	1
15	内转子 Inner rotor	N485-13102(A)	1
16	调整垫片 Adjusting shim	N485-13008(A)	1
17	机油泵盖 Oil pump cover	N85-13002(A)	1
18	垫片 Gasket	N85-13003	1
19	键 Key3×5×13	GB1099-79	1
20	机油泵轴 Oil pump shaft	N485-13101(A)	1



图11 燃油系统总成

Fig.11 Fuel System

## 燃油系统总成(图 11)

### Fuel System (Fig.11)

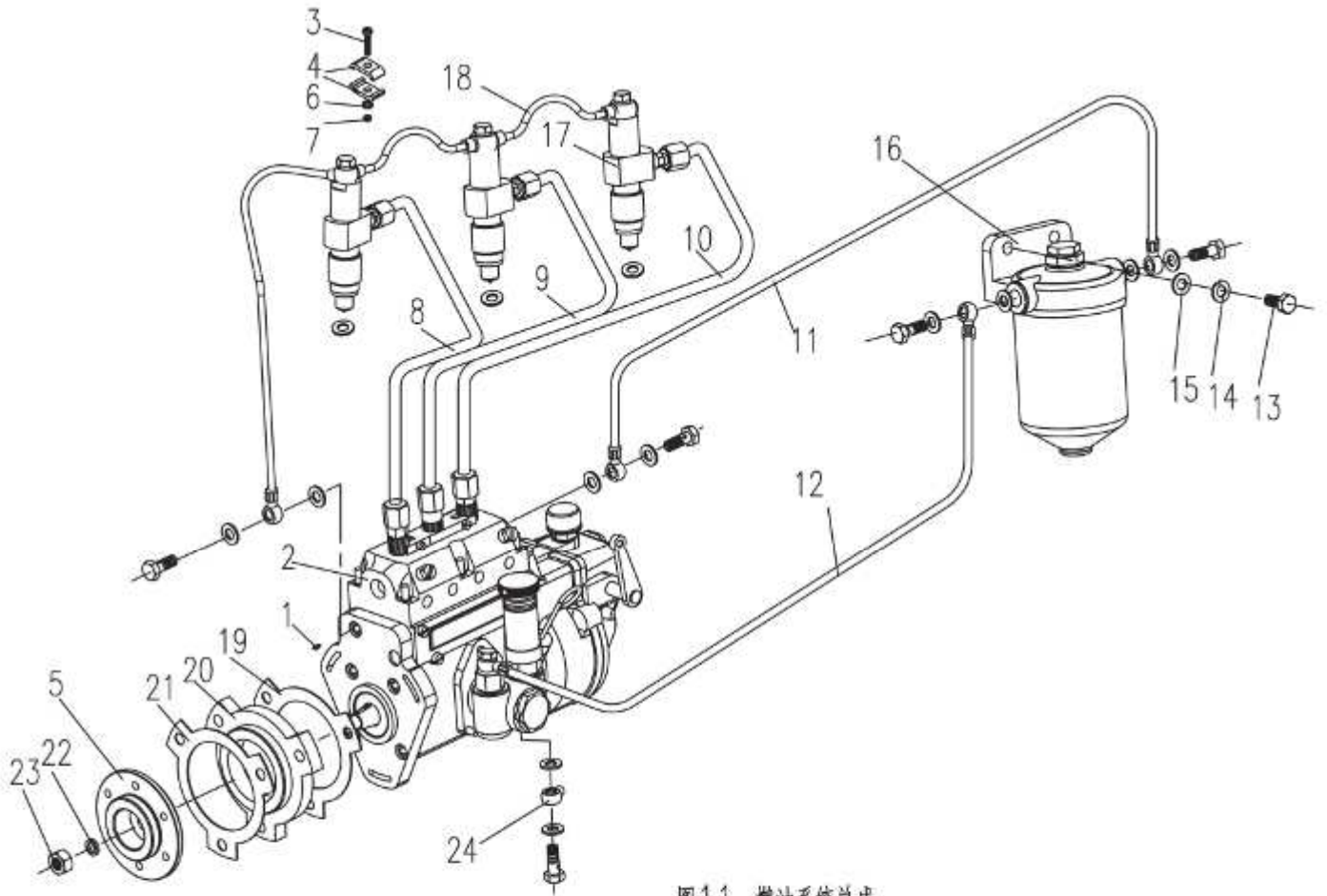
序号 Ref.No.	名称 Name of parts	零、部件号 Part No.	数量 Quantity
1	半圆键 Woodruff 3×16	GB1099-79	1
2	喷油泵总成 Injection pump	ZN390T-18000	1
3	圆柱头螺钉 Cylindrical screw M5×20	GB65-85	2
4	夹箍 Pipe clip(A)	N85-14001	4
5	喷油泵正时齿轮联接盘 Injection pump timing gear adapter	N85-18005	1
6	弹簧垫圈 Spring washer 5	GB859-87	2
7	螺母 nut M5	GB6170-86	2
8	第一缸高压油管部件 1 <sup>st</sup> cylinder high pressure fuel pipe	N385-14100	1
9	第二缸高压油管部件 2 <sup>nd</sup> cylinder high pressure fuel pipe	N385-14300	1
10	第三缸高压油管部件 3 <sup>rd</sup> cylinder high pressure fuel pipe	N385-15300	1
11	滤清器出油管部件 Fuel filter outlet pipe	N385-15300	1
12	输油泵出油管部件 Fuel feed pump outlet pipe	N385-15400	1
13	螺栓 Bolt M8×25	GB5782-86	2
14	垫圈 washer 8	GB859-87	2
15	垫圈 washer 8	GB848-85	2
16	柴油滤清器总成 Fuel filter	N485-28000	1
17	喷油器总成 Injector	ZN490QA-25000	3
18	喷油器回油管部件 Injector fuel return pipe	N390T-15100	1
19	喷油泵法兰垫片 Fuel pump flange gasket	N85-18002	1
20	喷油泵垫块 Injection pump end cover	N85-18003	1
21	喷油泵联接盘垫片 Injection pump adapter gasket	N85-18004	1
22	垫圈 washer 12	GB93-87	1
23	螺母 nut M12	GB6170-86	1
24	输油泵进油管接头部件 Fuel feed pump inlet connection	N85-15500	1



图12 机油集滤器总成

Fig.12 Oil suction Strainer Assembly

机油集滤器总成(图 12)

Oil Suction Strainer Assembly (Fig.12)

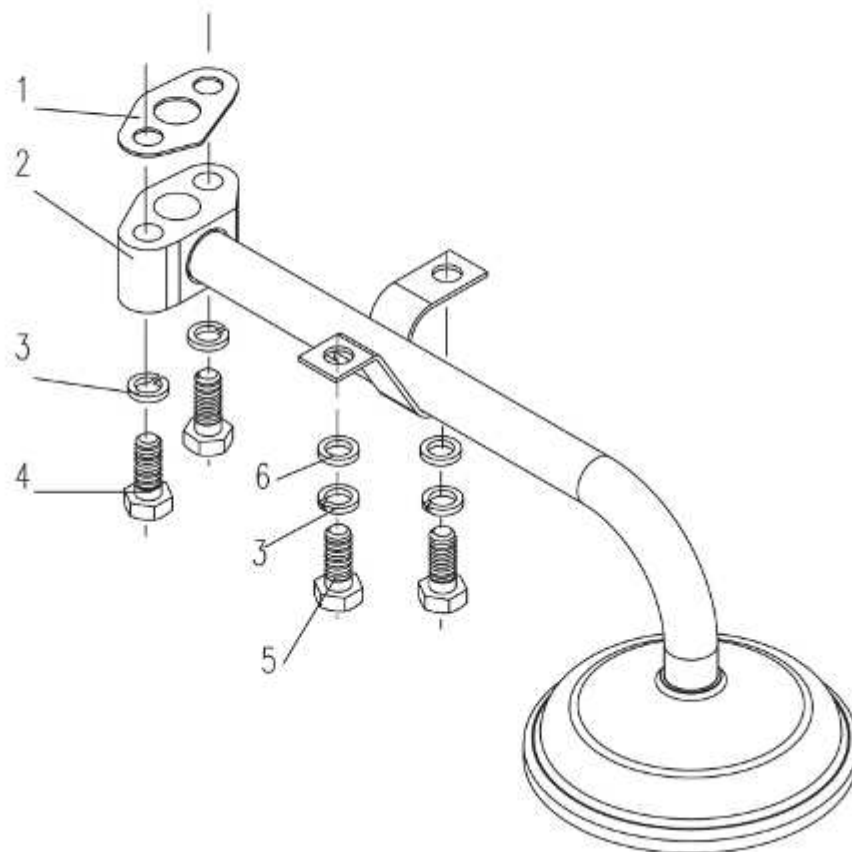
序号 Ref.No.	名称 Name of parts	零、部件号 Part No.	数量 Quantity
1	垫片 Gasket	N390T-16002	1
2	机油集滤器总成 Oil suction strainer	N390T-16000A	1
3	垫圈 washer 6	GB859-87	4
4	螺栓 bolt M6×35	GB5782-86	2
5	螺栓 bolt M6×16	GB5783-86	2
6	垫圈 washer 8	GB848-85	2



图13 呼吸器总成

Fig.13 Breather Assembly

呼吸器总成(图 13)

**Breather Assembly (Fig.13)**

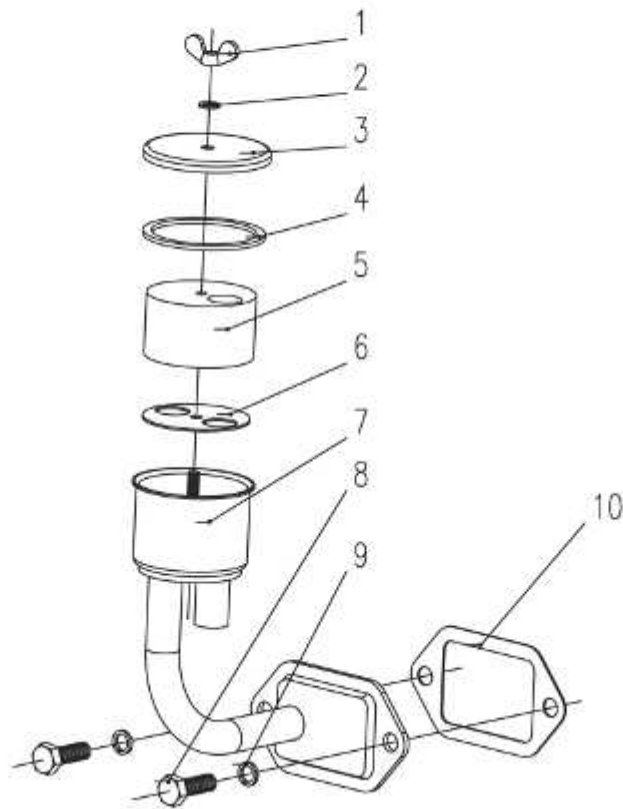
序号 Ref.No.	名称 Name of parts	零、部件号 Part No.	数量 Quantity
1	螺母 Nut	GB62-88	1
2	垫圈 Washer 5	GB97.1-85	1
3	呼吸器盖 Breather cover	N85-19001	1
4	密封垫圈 Seal ring	N85-19002	1
5	滤网 Cartridge	N85-19003	1
6	网挡 Cartridge retainer	N85-19004	1
7	呼吸器体焊合件 Breather body	N385-19100	1
8	螺栓 Bolt M8×16	GB5782-86	2
9	垫圈 Washer 8	GB859-87	2
10	推杆室盖垫片 Push rod case cover gasket	N85-19005	1



图14 机滤、空滤、发电机、起动电机、消声器

Fig.14 Oil Filter/Air Filter/Generator/Starting Motor/Silencer

机滤、空滤、发电机、起动电机、消声器(图 14)

**Oil Filter/Air Filter/Generator/Starting Motor/Silencer (Fig.14)**

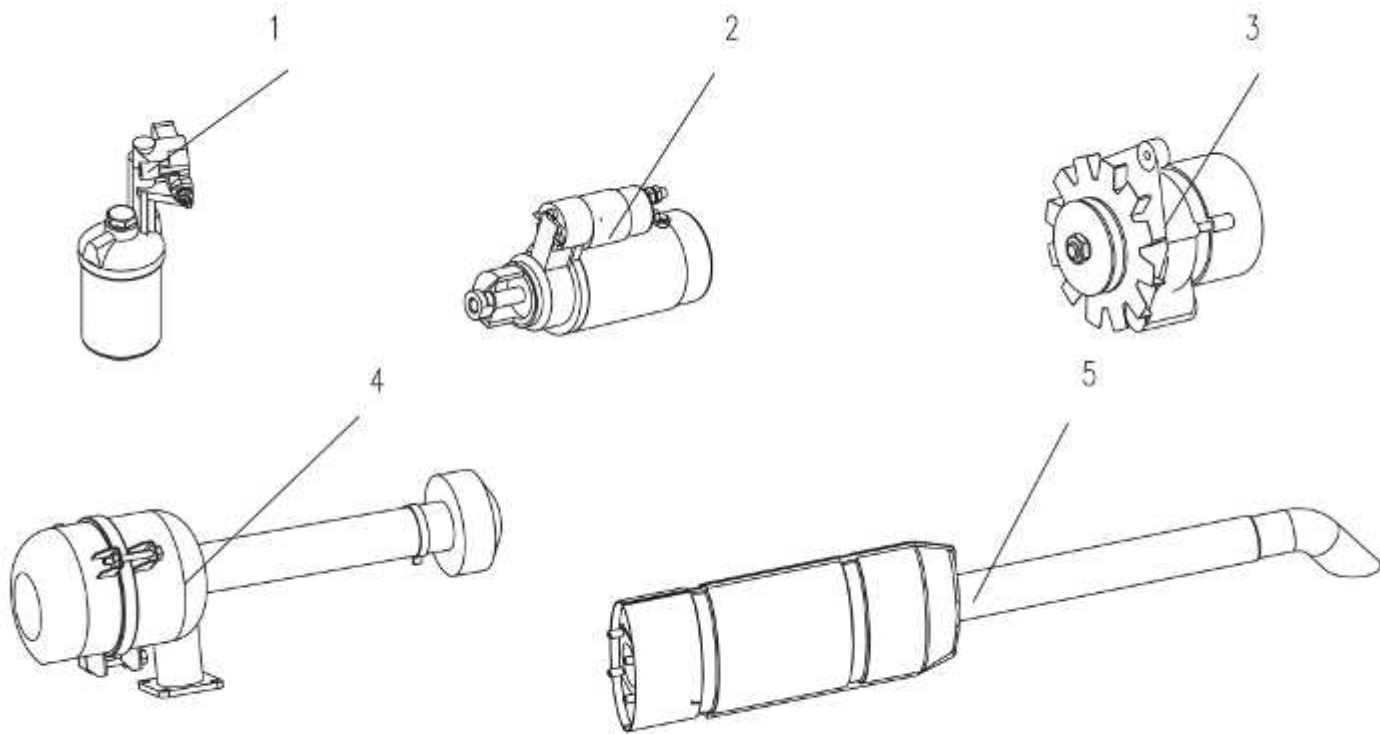
序号 Ref.No.	名称 Name of parts	零、部件号 Part No.	数量 Quantity
1	机油滤清器总成 Lubricating oil filter	N85T-16000A	1
2	起动电机总成 Starting motor	N485-30000	1
3	充电发电机总成 Charging generator	N85Q-29000	1
4	空气滤清器总成 Air filter	N390T-27000	1
5	消声器总成 Silencer	N85T-20000	1





图15 张紧轮部件

Fig.15 Tension pulley assembly

张紧轮部件(图 15)

Tension pulley assembly (Fig.15)

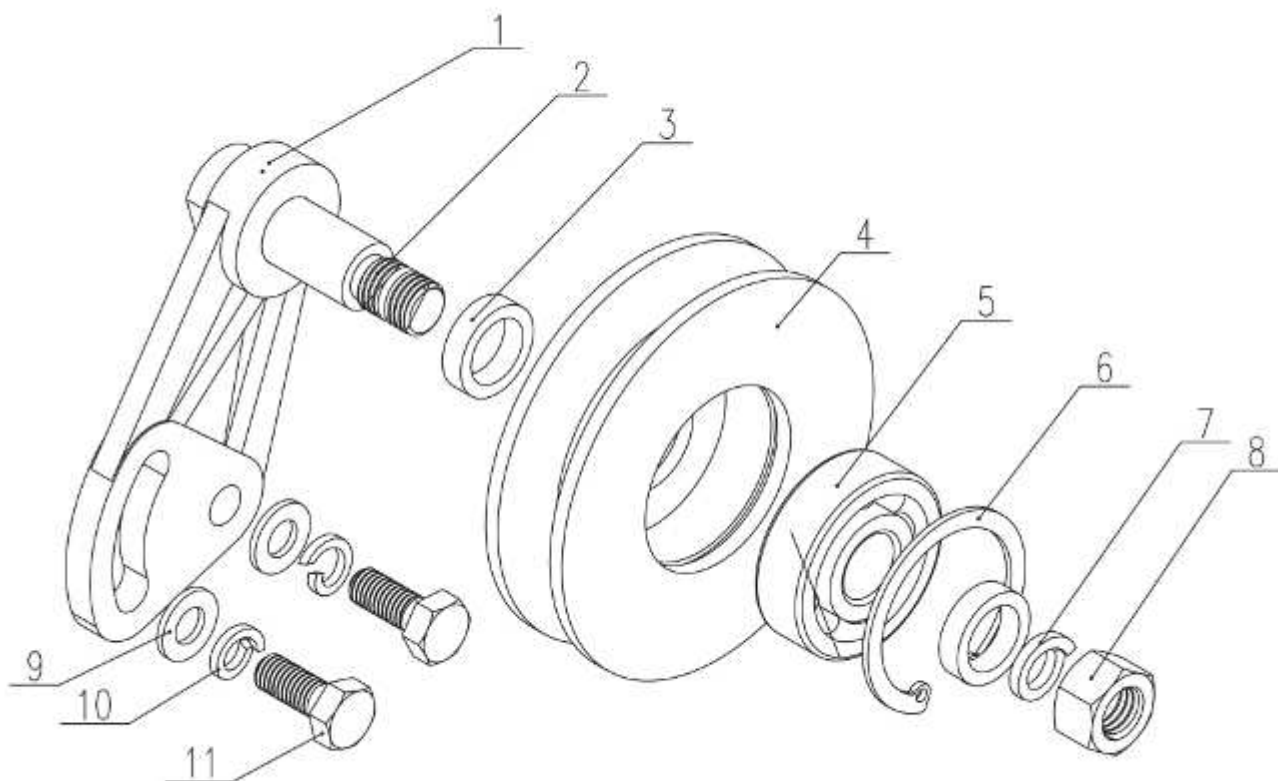
序号 Ref.No.	名称 Name of parts	零、部件号 Part No.	数量 Quantity
1	张紧轮支架 Tension pulley bracket	N390T-21002	1
2	张紧轮轴 Tension pulley shaft	N390T-21004	1
3	套圈 Bush ring	N390T-21003	2
4	张紧轮 Tension pulley	N390T-21001	1
5	轴承 Bearing 6302E-2RS	GB/T276-94	1
6	挡圈 Thrust ring 42	GB/T893.1-86	1
7	垫圈 Washer 12	GB/T93-87	1
8	螺母 Nut M12	GB/T6170-2000	1
9	垫圈 Washer 8	GB/T97.1-85	2
10	垫圈 Washer 8	GB/T93-87	2
11	螺栓 Bolt M8×20	GB/T5783-2000	2