

MCM



Technical Specifications

Engine

Machine	12RS
Model	CHANGCHAI 490
Type	Direct Injection, Water Cooled
No. of Cylinders	Diesel 4-cylinder Engine
Net Peak Power	39kW (52HP) @ 2400rpm
Fuel Tank Capacity	50 Litres

Transmission System

Type	Powershift	
Gears Forward/Reverse	2 Forward/2 Reverse	
Travel Speed	km/h	21
Max. Torque	Nm	195
Transfer Case	4WD	
Brake Control	Air Brake	

Operation Dimensions

A Total Travel Length	mm	4600
B Total Travel Height	mm	2400
Total Travel Width	mm	1760
C Wheel Base	mm	1360
Wheel Track	mm	1600
Bucket Width	mm	1760

Attachments

Augers	Breakers	Brush Cutters	Buckets	Earth Drills
Forks	Grapples	Rippers	Shears	And More

Operation Parameters

Operating Weight	kg	3500
Rated Load	kg	1200
Bucket Capacity	m ³	0.7
D Max. Dumping Height	mm	1950
E Max. Working Height	mm	2100
F Min. Dumping Distance	mm	485
Max. Dumping Angle	degrees	40-45
Max. Tractive Force	kN	36
Max. Breakout Force	kN	39
Hydraulic Flow Rate	L/min	77
System Pressure	MPa	16
Min. Turning Radius	mm	3800
G Min. Ground Clearance	mm	360

*Under our policy of continuous improvement, we reserve the right to change technical data and design without prior notice.

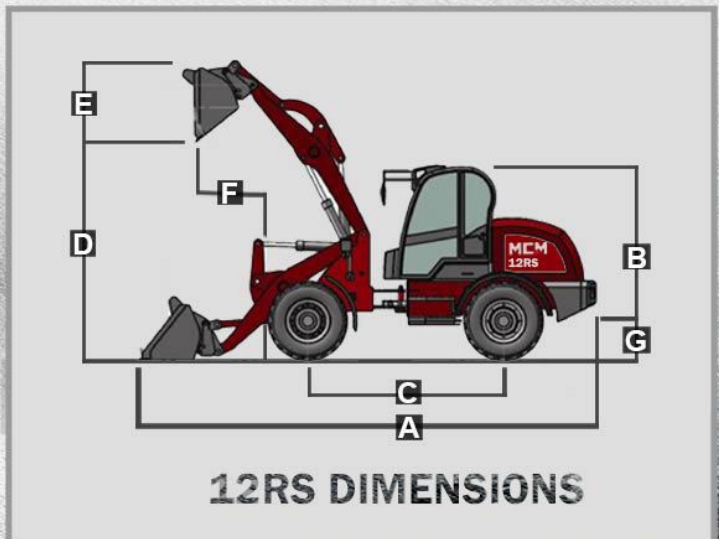

BUILDING THE FUTURE